



Modular Ice Machine User's Manual

194MCF322A, 194MCH322A, 194MCF422A, 194MCH422A, 194MCF530A,
194MCH530A, 194KMCF322BA, 194KMCH322BA, 194KMCF422BA, 194KMCH422BA,
194KMCF530BA, 194KMCH530BA, 194BIN23022, 194BIN27530, 194KMCF322LA,
194KMCH322LA, 194KMCF422LA, 194KMCH422LA, 194KMCF530LA,
194KMCH530LA, 194BIN40022, 194BIN54030, 194KMCF322HA, 194KMCH322HA,
194KMCF422HA, 194KMCH422HA, 194KMCF530HA, 194KMCH530HA,
194HBN12022, 194HBN18030

07/2022

*Please read the manual thoroughly prior to equipment set-up,
operation and maintenance.*

Table of Contents

1. Modular Ice Machine and Bin User's Manual

a. Warning and Safety.....	3
b. Installation.....	4
c. Startup and Operation.....	7
d. Maintenance.....	12
e. Clean Function.....	13
f. Manual Cleaning & Sanitizing.....	14
g. Service Call.....	17
h. Troubleshooting.....	18

2. Hotel Ice Dispenser User's Manual

a. General Description.....	21
b. Basic Specifications & Dimensioned Illustrations.....	21
c. Unpacking.....	26
d. Installation.....	27
e. Final Check List/Initial Start Up.....	29
f. Use.....	30
g. General Care and Cleaning.....	31
h. Maintenance.....	33
i. Adjustments.....	34
j. Service Diagnosis.....	35

3. Warranty

Warning and Safety

DANGER – RISK OF FIRE OR EXPLOSION. FLAMMABLE REFRIGERANT USED. TO BE REPAIRED ONLY BY TRAINED SERVICE PERSONNEL. DO NOT PUNCTURE REFRIGERANT TUBING.

PELIGRO - RIESGO DE INCENDIO O EXPLOSION. REFRIGERANTE INFLAMABLE UTILIZADO. PARA SER REPARADO SOLAMENTE POR PERSONAL DE SERVICIO CALIFICADO. NO PINCHAR LA TUBERÍA REFRIGERANTE.

DANGER – RISQUE DE FEU OU D'EXPLOSION. LE FRIGORIGÈNE EST INFLAMMABLE. CONFIER LES RÉPARATIONS À UN TECHNICIEN SPÉCIALISÉ. NE PAS PERFORER LA TUBULURE CONTENANT LE FRIGORIGÈNE.

CAUTION – RISK OF FIRE OR EXPLOSION. FLAMMABLE REFRIGERANT USED. CONSULT REPAIR MANUAL/OWNER'S GUIDE BEFORE ATTEMPTING TO SERVICE THIS PRODUCT. ALL SAFETY PRECAUTIONS MUST BE FOLLOWED.

ATENCIÓN - RIESGO DE INCENDIO O EXPLOSIÓN. REFRIGERANTE INFLAMABLE UTILIZADO. CONSULTE EL MANUAL DE REPARACIÓN / GUÍA DEL PROPIETARIO ANTES DE INTENTAR DAR SERVICIO A ESTE PRODUCTO. DEBEN CUMPLIR CON TODAS LAS PRECAUCIONES DE SEGURIDAD.

ATTENTION – RISQUE DE FEU OU D'EXPLOSION. LE FRIGORIGÈNE EST INFLAMMABLE. CONSULTER LE MANUEL DU PROPRIÉTAIRE/GUIDE DE RÉPARATION AVANT DE TENTER UNE RÉPARATION. TOUTES LE MESURES DE SÉCURITÉ DOIVENT ÊTRE RESPECTÉES.

CAUTION – RISK OF FIRE OR EXPLOSION DUE TO PUNCTURE OF REFRIGERANT TUBING; FOLLOW HANDLING INSTRUCTIONS CAREFULLY. FLAMMABLE REFRIGERANT USED.

ATENCIÓN - RIESGO DE INCENDIO O EXPLOSIÓN DEBIDO A LA PERFORACION DE LA TUBERÍA REFRIGERANTE; SIGA LAS INSTRUCCIONES DE MANIPULACIÓN CON CUIDADO. REFRIGERANTE INFLAMABLE UTILIZADO.

ATTENTION – RISQUE DE FEU OU D'EXPLOSION SI LA TUBULURE CONTENANT LE FRIGORIGÈNE EST PERFORÉE; SUIVRE LES INSTRUCTIONS DE MANUTENTION AVEC SOIN. LE FRIGORIGÈNE EST INFLAMMABLE.

CAUTION – RISK OF FIRE OR EXPLOSION DUE TO FLAMMABLE REFRIGERANT USED. FOLLOW HANDLING INSTRUCTIONS CAREFULLY IN COMPLIANCE WITH LOCAL GOVERNMENT REGULATIONS.

ATENCIÓN – RIESGO DE INCENDIO O EXPLOSIÓN DEBIDO A REFRIGERANTE INFLAMABLE UTILIZADO. SIGA LAS INSTRUCCIONES DE MANIPULACIÓN CON CUIDADO CONFORME A LAS REGLAS DE LA MUNICIPALIDAD.

ATTENTION – RISQUE DE FEU OU D'EXPLOSION SI LE FRIGORIGÈNE EST INFLAMMABLE. SUIVRE LES INSTRUCTIONS DE MANUTENTION AVEC SOIN CONFORMÉMENT AUX RÈGLEMENTATION GOUVERNEMENTALE LOCAUX.

This product cannot be used in outdoor environments. Not intended for use by children, persons with reduced physical, sensory or mental capabilities or lack of experience and knowledge.

- The installation, repair or maintenance of this ice machine must be carried out by professional and qualified personnel. Electric shock, fire, personal injury may result from incorrect operation.
- After the ice machine is delivered, please keep the machine upright for at least 24 hours to have the refrigerant be fully precipitated before startup. Otherwise the compressor may be damaged.
- When handling, keep the cabinet upright with the inclination not exceeding 45 degrees. Do not invert the machine or lay it horizontally.
- This ice machine should not be placed in wet or easily splashed areas.
- The grounding of this ice machine cannot be connected to a gas pipe, water pipe, telephone line or lightning rods, etc.
- There are rotating components in this ice machine. Do not insert slim objects into ventilation or exhaust ports, or serious mechanical damage and injury may occur.
- Do not store volatile or flammable substances in this ice machine or it may result in an explosion or fire.
- Do not store any sundries or freeze any food in the storage bin. Keep the ice scoop clean.
- The ice machine must be placed on a floor sufficient enough to support its weight. An insufficient base may cause the equipment to fall over and cause injury.
- There should be sufficient ventilation space around the ice machine. See page 5 for clearance requirements.
- Only the power supply specified on the machine nameplate can be used with this ice machine.
- This ice machine cannot be connected to hot water.
- Outlet for this ice maker must be reliably grounded with leakage protection.
- The ice machine must be disconnected from power before manual cleaning, repairing and maintenance.
- Before cleaning, repairing and maintenance, the remaining ice in the ice bin should be removed from the ice machine to avoid contamination to ice.
- Do not splash water directly onto the surface of the ice machine during the cleaning process; otherwise it may cause short circuit, leakage or other faults.
- Flammable foaming agent is used during the foaming process. The ice maker should be disposed of and recycled by qualified personnel and institutions.
- The ice machine should be properly managed to ensure that children will not play with the machine.
- When the ice machine malfunctions, turn off the power and contact professional personnel to be repaired.

User Manual



This ice machine is fully automatic. With proper installation and connection to potable water and power source, the ice making will start properly. When the ice cubes fill up the storage bin, the machine will automatically stop. The ice machine is generally used in the following and similar occasions:

- Indoor, ambient controlled environments only.
- The kitchen area of a store, office or other workplace;
- Hotel and restaurant;
- Catering and similar non-retail occasions;
- This ice machine is not intended for residential use



C Pure creates specialty water filters to be used with common restaurant equipment, ensuring that the water utilized by the equipment is both clean and clear. These filters are easily installed into water lines, and their cartridges can be quickly swapped out for fast, easy and efficient replacements. The water filters below are approved for use with Avantco Ice Machines. Failure to use and maintain an appropriate water filter will void warranty coverage on your Avantco Ice Machine. For installation instructions, refer to the C Pure water filtration manual or contact a C Pure water filtration dealer.

Modular Ice Machine

Item Number	Ice Shape	Ice Production Per 24 Hrs.	Recommended Water Filtration System	Replacement Cartridge
194MCF322A	Full Dice	350 lbs.	790CLOCKITM	790CLOCARTM
194MCH322A	Half Dice	350 lbs.	790CLOCKITM	790CLOCARTM
194MCF422A	Full Dice	420 lbs.	790CLOCKITM	790CLOCARTM
194MCH422A	Half Dice	420 lbs.	790CLOCKITM	790CLOCARTM
194MCF530A	Full Dice	500 lbs.	790CLOCKITM	790CLOCARTM
194MCH530A	Half Dice	500 lbs.	790CLOCKITM	790CLOCARTM

User Manual



Modular & Bin

Item Number	Ice Shape	Ice Production Per 24 Hrs.	Recommended Water Filtration System	Replacement Cartridge
194KMCF322BA	Full Dice	350 lbs.	790CLOCKITM	790CLOCARTM
194KMCH322BA	Half Dice	350 lbs.	790CLOCKITM	790CLOCARTM
194KMCF422BA	Full Dice	420 lbs.	790CLOCKITM	790CLOCARTM
194KMCH422BA	Half Dice	420 lbs.	790CLOCKITM	790CLOCARTM
194KMCF530BA	Full Dice	500 lbs.	790CLOCKITM	790CLOCARTM
194KMCH530BA	Half Dice	500 lbs.	790CLOCKITM	790CLOCARTM
194KMCF322LA	Full Dice	350 lbs.	790CLOCKITM	790CLOCARTM
194KMCH322LA	Half Dice	350 lbs.	790CLOCKITM	790CLOCARTM
194KMCF422LA	Full Dice	420 lbs.	790CLOCKITM	790CLOCARTM
194KMCH422LA	Half Dice	420 lbs.	790CLOCKITM	790CLOCARTM
194KMCF530LA	Full Dice	500 lbs.	790CLOCKITM	790CLOCARTM
194KMCH530LA	Half Dice	500 lbs.	790CLOCKITM	790CLOCARTM

Modular & Hotel Dispenser

Item Number	Ice Shape	Ice Production Per 24 Hrs.	Recommended Water Filtration System	Replacement Cartridge
194KMCF322HA	Full Dice	350 lbs.	790CLOCKITM	790CLOCARTM
194KMCH322HA	Half Dice	350 lbs.	790CLOCKITM	790CLOCARTM
194KMCF422HA	Full Dice	420 lbs.	790CLOCKITM	790CLOCARTM
194KMCH422HA	Half Dice	420 lbs.	790CLOCKITM	790CLOCARTM
194KMCF530HA	Full Dice	500 lbs.	790CLOCKITM	790CLOCARTM
194KMCH530HA	Half Dice	500 lbs.	790CLOCKITM	790CLOCARTM

Installation

The ice machine should be installed in a proper location meeting the following conditions:

- Indoors, ambient temperature: 40-90°F;
- Power supply: the rated voltage indicated on the machine nameplate $\pm 6\%$;
- Water source: potable water, with water pressure from 18.75 psi to 80 psi; water temperature: 40-90°F;
- The ice machine should be kept away from heat sources, and should be prohibited to use in an extremely high or low temperature environment, and should avoid direct sunlight.
- There should be sufficient ventilation space around the ice machine; the distance from the ice maker to the wall should be no less than 12" for the front, 6" for the sides, and 8" for the rear.
- The ice machine must be placed on a floor sufficient to support its weight;
- The socket for the ice maker must be reliably grounded and have leakage protection;
- Proper floor drainage must be provided near the installation location of the ice machine.

Schematic Diagram

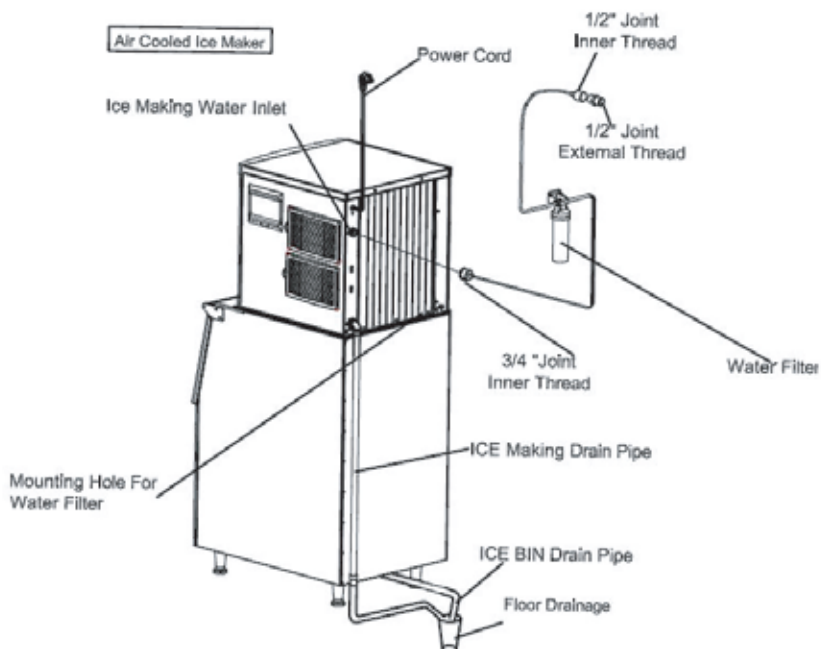

Installation Steps

1. Check to see if the ice machine is in good condition and the accessories are all present; check the machine model and the machine nameplate.
2. Clean the ice storage bin and the food area inside with a sponge soaked in warm water and soap. Then rinse with potable water and dry.
3. Place the ice machine in the operation area; ensure that the machine is placed on a leveled floor so the water flows evenly into the evaporator.
4. The compressor chamber is located below the front of the ice bin where the compressor and condenser are installed. It requires good ventilation so the ice maker must have ventilation space of more than 8" in the rear, 6" on the sides, and 12" in the front.
5. The bottom of the ice machine is equipped with adjustable legs for level adjustment and clearance for floor cleaning.
6. Connect the machine's inlet water filter and water line referring to the installation instructions of your water filter brand; if the installation site is already equipped with a drinking water system, the water filter may not be needed.
7. Connect the machine to the water supply using the 3/4" inlet fitting supplied with the machine. It is recommended to install a water ball valve (not supplied with this machine) on the water supply line.
8. Connect the drain line to the drain connector. To achieve a proper draining, it is recommended that the drain pipe should have a difference in level of more than 1" per 3'; and confirm that the drain line is not blocked. It is recommended that the drain line be connected to an open drainage port.
9. Any joint in the drain line must not be higher than the machine drainage port; any joint in the drain line cannot be higher than the previous joint.
10. Confirm the power requirements stated in the machine's nameplate; ensure that the power supply meets the requirements.
11. A circuit breaker or switch with leakage protector and reliable grounding is required.
12. Turn off the switch on the power line and connect the machine to the power source.

NOTE: the filter flow direction should be correctly installed as per the direction marker on the filter head cover or the filter body. The filter cartridge should be replaced every 3 to 6 months.

Startup and Operation

1. Before you start up the machine, please check and confirm:
 - That the packaging tape inside the ice machine has been removed;
 - The accessories or items in the ice bin have been taken out;
 - The ice machine has been adjusted to a leveled state;
 - The water line has been connected and the water valve is open;
 - The plug has been connected to the power supply and the power switch is off.
 - The ambient temperature, water temperature, and pressure of the water supply meet the above requirements.
2. Start up: turn on the power switch. After power-on, the machine begins to make ice automatically.
3. For normal operation, please confirm:
 - There is water in the water trough and no overflow occurs;
 - The pump is working properly and water is flowing evenly in the evaporator;
 - The compressor is running normally, the temperature of the evaporator and the ice making water is gradually decreasing;
 - For air cooled machines, make sure the fan is running normally, and there is stable air flow in the inlet and outlet of the ice machine;
 - The ice machine has no abnormal noise;
 - The ice machine has no abnormal vibration;
 - It takes about 10 to 20 minutes to make one batch of ice, depending on the ambient temperature and the temperature of the water. The higher the temperature is, the longer the ice making will take;
 - Ice cubes can be properly harvested from the machine.

Operation Instructions

- **Startup:** after proper installation, connect the water source and turn on the power supply to turn on the machine. Please confirm that the machine is operating normally when you turn it on for the first time.
- **Self-check:** with power on for the first time, the ice maker will do a self-check and pump out any remaining water.
- **Preparing:** after the ice machine has finished the self-check, the inlet valve opens and the inlet water will flow in until it reaches the set level; then the ice maker will defrost one time.
- **Ice making:** after pre-cooling for 30 seconds, the water pump starts, the water flows through the evaporator smoothly and evenly, the ice cubes are gradually formed in the ice cube tray.
- **Ice Harvest (Drop):** after the ice making process finishes and the water pump is turned off, the defrosting valve is turned on. After the hot gas enters into the evaporator for about 1-2 minutes the ice cubes slide from the evaporator into the storage bin.

Warning: Do not put your hand into the ice storage bin during the ice-falling process to prevent the ice from hitting your hand!

- **Shutdown:** The ice maker will stop working when you push the "on/off" button on the control panel during the running process.
- **Bin full stop:** Once the ice storage bin is filled to a certain height, the ice making process will stop after 40 seconds. There is a sensor at the top of the bin which will trigger this stop in production. In order to maximize the bin space make sure to spread around the ice that piles up in front of the sensor
- **Repeat ice-making:** When the ice cubes triggering this sensor are moved or taken away, the ice maker will go back to the ice making process within seconds

Control Panel

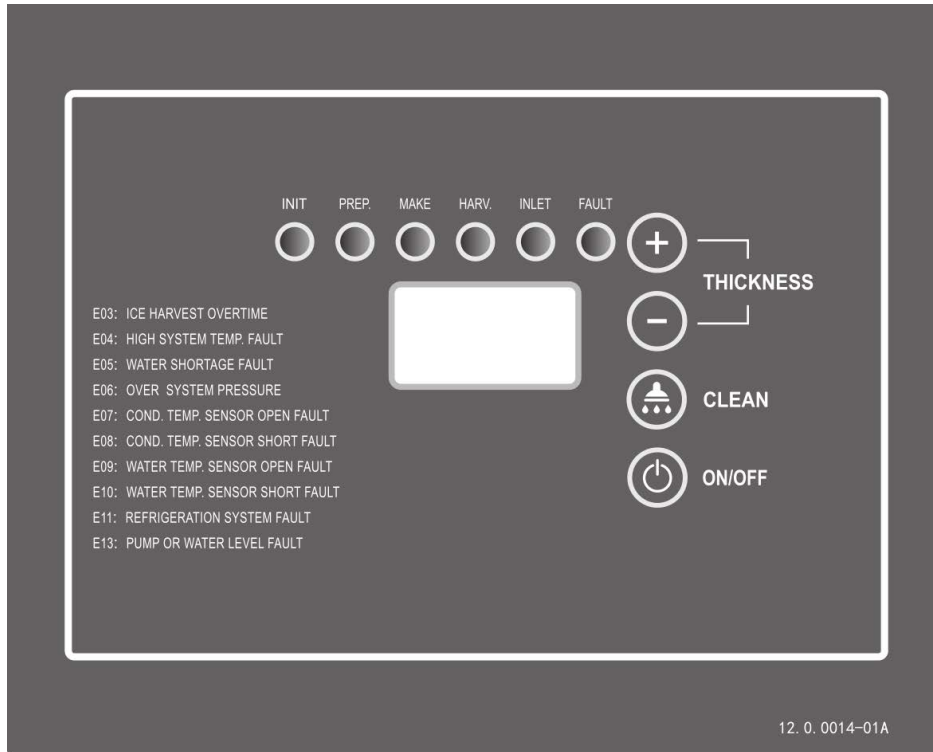

1. LED Display:

- Self-check: Display “ini” code.
- Preparing: Counts (in seconds) forwards.
- Ice making: Counts (in seconds) forwards prior to the water reaching 32 degrees F. Counts seconds backwards to 0 seconds afterwards.
- Ice Harvest: Counts (in seconds) forwards.
- Clean: Display “CLE” during cleaning and descaling; Display “STL” during sanitizing; Display “RIN” during rinsing.

2. LED Lamps: Turns lights on/off

3. Ice cube thickness adjustment: During the ice making process, if you are not satisfied with the ice thickness, press the Ice cube “-” button for 3 seconds, then click the button “+” or “-” on the panel to adjust the thickness of ice cube.

- Note: By clicking the “+” or “-” button one time, the ice making time is extended or shortened by 1.5 minutes.

4. Cleaning: During the normal operation, hold the cleaning button for 3 seconds to enter the cleaning process. During the entire cleaning process, cleaning agents and disinfectants need to be put into the water trough. When the cleaning process is finished, the ice maker will go to the ice making process.

Note: All cleaning and sanitizing chemicals used must be nickel safe

5. ON/OFF: Press this button to switch the machine OFF/ON.

6. Please open and close the storage bin door gently. Do not slam the door. Keep door closed when not removing ice.

7. If the ice maker is not in use for a long time, it should be energized and run for 2 to 4 hours every 2 months.

Other Special Protection - Shutdown

- If the ice machine has not detected ice harvest in three cycles, it will shut down for safety and protection. The ice maker needs to be checked.
- If the ice machine detects that the ambient temperature is too high it will stop for safety and protection.
- The fault code and its comments are displayed as follows:

Code	Comments	Machine Action
E01	Evaporator failure	Protective shutdown
E02	Ice making time out	Protective shutdown
E03	Overtime of ice making	Protective shutdown
E04	High temperature	Protective shutdown
E05	Water shortage	Protective shutdown
E06	High pressure	Protective shutdown
E07	Condensation sensor open circuit	Does not shutdown, Error LED light on every 5 seconds
E08	Condensation sensor short circuit	Does not shutdown, Error LED light on every 5 seconds
E09	Evaporator sensor open circuit	Does not shutdown
E10	Evaporator sensor short circuit fault	Does not shutdown
E11	Refrigeration system failure	Protective shutdown
E12	Water level control fault	Protective shutdown
E13	Pump or water level fault	Protective shutdown



Noble Chemical offers a full line of products to clean and sanitize your commercial ice machine. These chemicals are approved for use with Avantco Ice Machines. Failure to regularly clean and sanitize your Avantco Ice Machine will void warranty coverage. For information and instructions, contact a Noble Chemical dealer. The ice machine needs to be cleaned every other month, or once a month for high yeast environments.

Cleaners

Item Number	Size	Type
147ARCTIC	16 oz.	Concentrate
147ARCTICRPT	16 oz.	Ready to use
147ARCTICR1G	1 Gallon	Ready to use

Sanitizers

Item Number	Size	Type
147QKSANICE	12 Pack/16 oz. Bottles	Concentrate
999QKSANICE	16 oz.	Concentrate

Maintenance

NOTE: Maintenance must be done by a qualified technician.

WARNING: Before maintenance or manual cleaning, be sure to shut off the water source and power supply.

Exterior Cleaning

- Frequently clean the environment around the ice machine to keep it clean.
Do not block the vents.
- The outer enclosure should be cleaned with a mild detergent and then wiped clean.
If necessary, use commercial stainless steel cleaners and polishes.

NOTE: Stainless steel may rust without proper maintenance.

Inlet Water Filter

- The water filter should be inspected regularly. It is recommended to replace the filter cartridge every 3 to 6 months.

Interior Cleaning

- The inside of the ice storage bin can be washed with water and cleaner solution.
Rinse thoroughly with water. Repeat this process with a water and sanitizer solution.
- Note: Check and confirm the water pressure is lower than the maximum allowed pressure.
Do not flush the part above the water pump or the evaporator directly for water protection.

Condenser

- For the air-cooled ice maker, the condenser should be cleaned every three weeks. Use a soft brush or a vacuum cleaner with a brush to brush it up and down along the fin direction, to avoid damage to the fins and further affecting the cooling effect.
- The condenser filter should be cleaned every 2 weeks.

NOTE: Be careful when cleaning the condenser as the edges of the fins are sharp.

Water Line

- In order to ensure food safety, the water line of the ice machine should be cleaned regularly.

Winterizing

- Turn off the water and power supply, drain the residual water from the water trough inlet pipe and drain pipe.

NOTE: The maintenance of the ice machine is not covered by the manufacturer's warranty!

Clean Function

NOTE: Please empty the bin of ice in advance.

NOTE: Please clean and sanitize the bin and do a complete rinsing.

NOTE: Please clean and sanitize the ice sliding board, water distribution line, water supply line, water pump, then do a complete rinsing.

- Turn on the ice maker; push “clean” button for 3 seconds, the ice maker will begin the cleaning process. Put in the proper amount of cleaning solution manually into the water trough until it reaches the normal operating water level.
- Push the “clean” button. The ice maker will do auto clean for about 15 minutes. Please spray the evaporator with the cleaning solution in the meantime to ensure a complete clean. When finished, the LED display will flash "Clean" slowly again.
- Put in the proper amount of sanitizing solution manually into the water trough followed by the clean and sanitizing process instruction. Push the “clean” button again, the ice maker will do auto sanitizing for about 15 minutes. Please spray the evaporator with the sanitizing solution in the meantime to ensure complete sanitization. When finished, the ice maker will go into the rinsing process, this process will take about 5 minutes, and do 5 rinsing cycles. Refer to your cleaner and sanitizer for proper mixing & coding instructions.
- The ice maker will go back to making ice as soon as the cleaning process ends.
- Please throw away the next batch of ice in case of residual cleaner.

Manual Cleaning & Sanitizing

Cleaning Instructions



1. Remove all ice from the ice bin to avoid contamination.

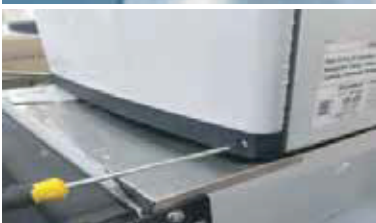

2. Remove the 4 screws from the top and bottom of the ice machine's front panel and remove the front panel.

3. To empty the water from the tank while the machine is running, press and hold the “Clean” button for 3 seconds and enter the cleaning mode to display CLE. In the cleaning mode, press the “-” button for 3 seconds to drain.

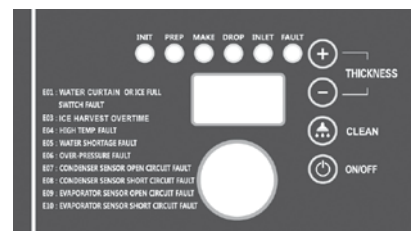

Note: Cut off the power supply after draining

User Manual

4. Make sure the power supply is cut off. Remove the water curtain.



5. Remove the 2 screws which are securing the spray pipe and remove it.



6. Remove the 2 screws which are securing the water pump.



7. Pull out the pump and sensor wiring harness.

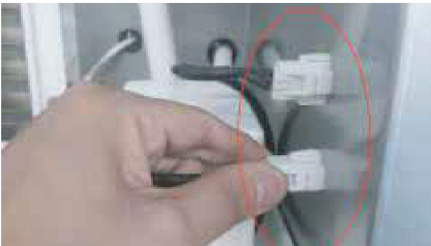

8. Pull out inlet water pipe.



9. Pull out the hose hoop of the upper water pipe.



10. Disassemble fixed screws which are in the spray pipe. Dismantle the spray pipe.



11. After soaking, scrub the spray pipe, water curtain and pump base bracket with cleaning solution, and rinse with clean water.



12.

Sanitizing Instructions

1. Mix a solution of sanitizer and water according to your ice machine sanitizer instructions. Ensure the sanitizer dissolves completely. Soak the water pipe, inner and outer spray pipe, head spray pipe fixing seat and screws, etc. in the solution for 5 minutes. If using a no-rinse sanitizer, there is no need to rinse.



Service Call

If the ice machine works abnormally, please confirm below before making a service call:

1. Check the water supply

- Whether there is water in the water trough;
- Whether the water pressure is 18.75 psi to 80 psi; the water temperature is 40-90°F;
- Whether the water valve is open;
- Whether there is no water leakage;

2. Check the power

- Whether the indicator on the display panel is ON;
- Whether the panel display does not display the OFF standby state;
- If the LED on the display panel is not ON, check whether the plug and socket are normal, and whether the power supply switch is ON.

3. Check nameplate and serial number

- Check the nameplate located on the side or back of the ice machine and record the model and series number of the ice machine.

Note: If the machine fails due to the user's faults, such as failure to use and maintain a water filter, no supply of water, electricity or environmental factors, rather than the fault of the ice maker, the door-to-door service will be charged.

Troubleshooting

Fault	Potential Cause	Troubleshooting
Not working	Power switch not turned on	Turn on the power switch
Indicator is OFF	Plug is loose	Check plug and socket
Shutdown every 3 minutes after startup;	The ambient temperature is too high	Normal working temperature range of 41-95°F
The display shows E04 high temperature	Condenser is dirty and blocked High pressure switch wires fallen off	Clean the condenser
The display shows E06 high pressure protection	Fan does not start	Check and correct high pressure switch wires Check and correct the fan
Ice defrost abnormal	Ambient temperature too low	Normal working temperature range of 41-95°F
	Defrost valve does not start normally	Check and correct the defrosting valve
	Ice thickness too thin or too thick	Check and correct ice thickness setting

User Manual

Poor transparency of ice cubes; ice cubes too thin or incomplete	Ice thickness is too thin	Check and correct ice thickness setting
	Water pressure is too low	Check that the water supply pressure is 1.3 bar to 5.5 bar
	Water temperature is too high	Normal working temperature range of 41-95°F
	Inlet water valve does not work	Check and correct the inlet water valve
	Inlet water valve is dirty and blocked	Check whether water leaks and correct
	Water leaking	Check and correct the inlet water filter and water connection
	Inlet water filter has not been replaced for a long time	
Too slow in ice making	The condenser or air filter is dirty	Clean the condenser and filter screen
	High ambient temperature	Normal working temperature range of 41-95°F
	Poor ventilation	Check the environment around the ice machine
	Water temperature is too high	Check the water supply temperature of 41-95°F
Too much noise	The ice machine is not placed in a leveled foundation or the ice maker is not leveled	Level the ice machine



Hotel Ice Dispenser User's Manual

Models: 194HBN12022, 194HBN18030

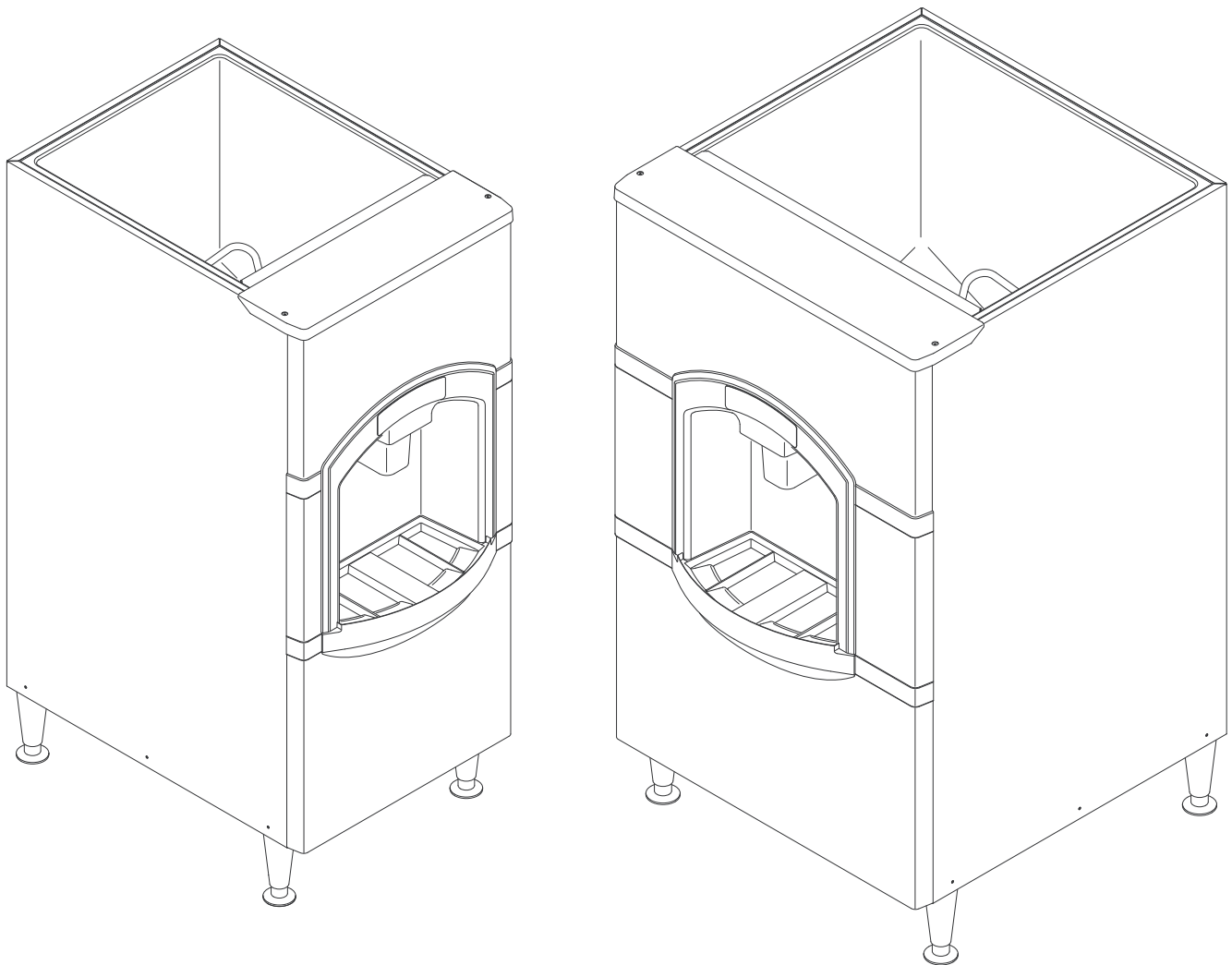

General Information

The 194HBN12022 22"W and is designed to use an Avantco Ice 194MC35022HA/FA or 194MC42022HA/FA cube ice machine as the source for ice production.

The 194HBN18030 is 30"W and designed to use an Avantco Ice 194MC50030HA/FA cube ice machine as the source for ice production.

Ice from the cuber falls into the insulated hopper, where it is stored until needed. When a user pushes the dispense chute a rotating wheel scoops the ice up to the top front of the hopper where there is an outlet to the ice chute.

Cuber Model	Fits Dispenser	Adapter
194MCF322A/194MCH322A	194HBN12022	194BKTHBN
194MCF422A/194MCH422A	194HBN12022	194BKTHBN
194MCH530A/194MCF530A	194HBN18030	194BKTHBN

Basic Specifications

Model	Dimensions w"xh"xd" with 6" leg	Basic Electrical volts/hertz/phase	Model Description	Bin Storage Capacity
194HBN12022	22 x 53 x 33 ½	115/60/1	Basic 22" model	60 Hz 120 lb
194HBN18030	30 x 53 x 33 ½	115/60/1	Basic 30" model	60 Hz 180 lb

Specifications & Limitations

This ice dispenser is designed to be installed and operated indoors in a controlled environment. Follow the Installation Instructions in the Ice Machine Manual to ensure the ice machine has been installed properly.

	Minimum	Maximum
Air Temp	50 °F.	100 °F.
Voltage 60 Hz	104	126

Check the nameplate, located on the back of the cabinet for specific information.

Avantco Ice Machines assumes no liability or responsibility of any kind for products manufactured by Avantco Ice Machines that have been altered in any way, including the use of any parts and/or other components not specifically approved by Avantco Ice Machines.

194HBN18030 Dimensioned Illustration

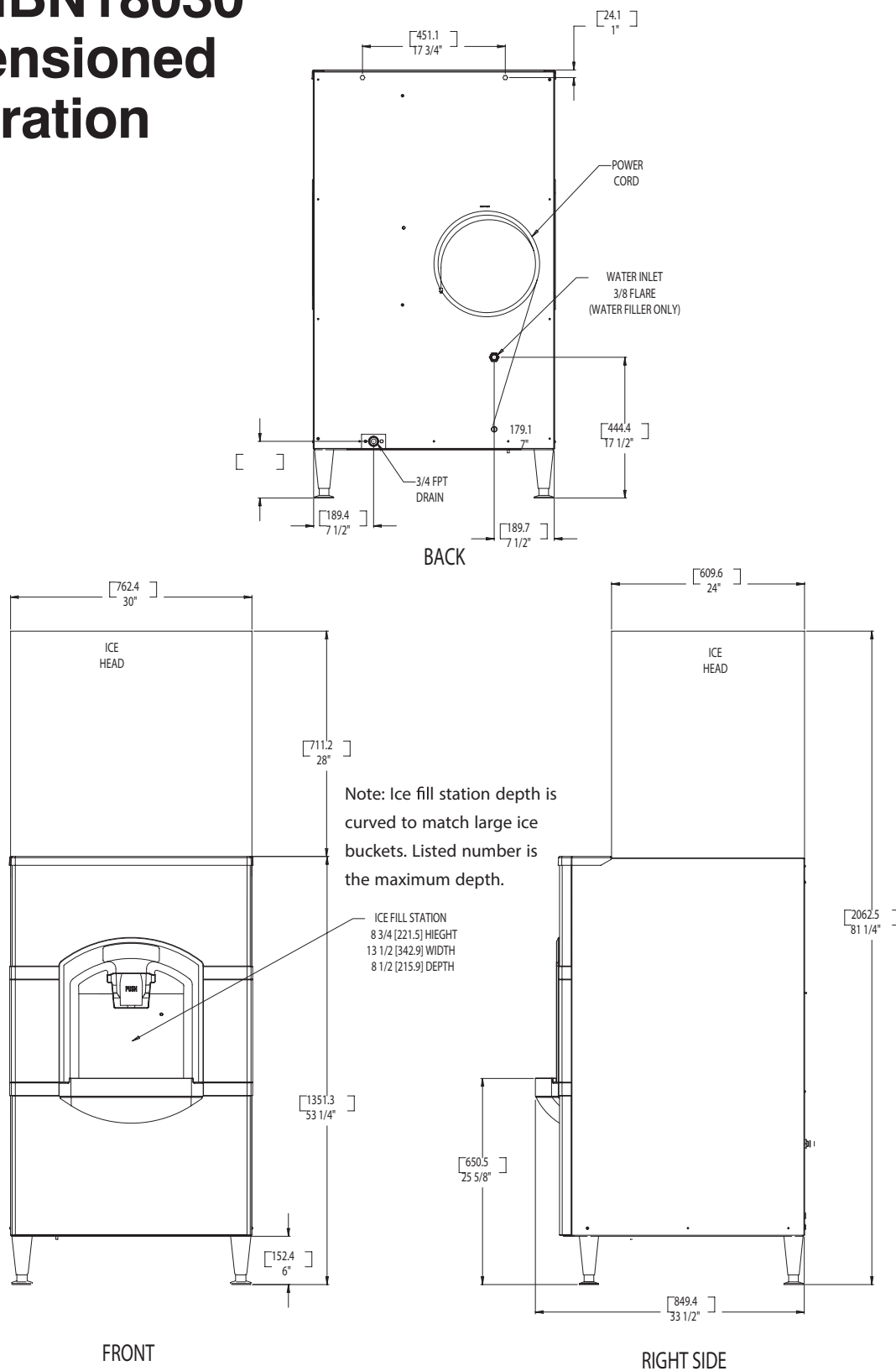

User Manual

194HBN12022 Dimensioned Illustration

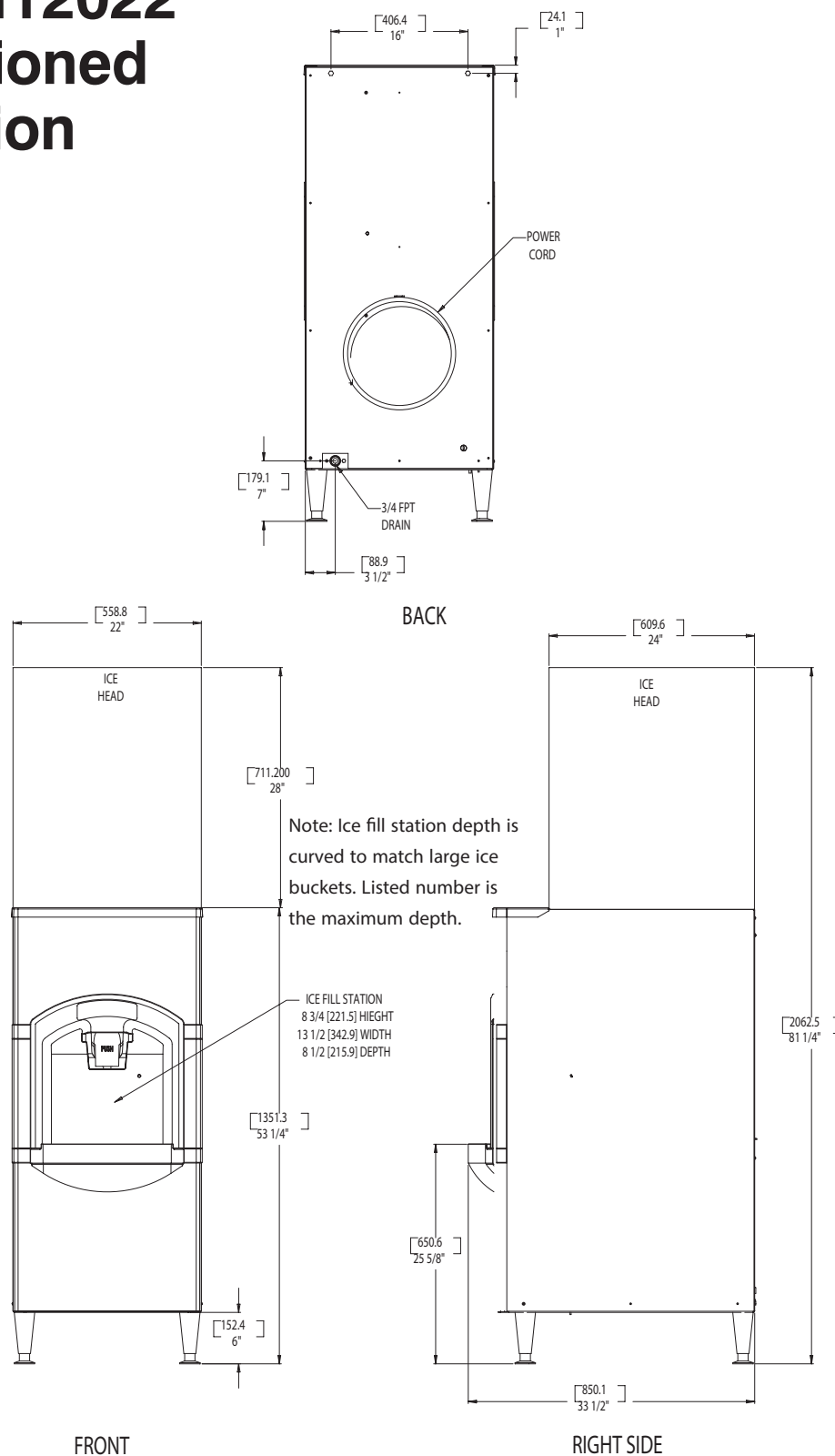

Product Description

All models consist of a plastic lined, insulated hopper mounted to a metal base. The hopper contains a 15 blade plastic dispense wheel and a stainless steel sweep arm. The top front of the hopper has a removable door to facilitate maintenance and cleaning of the hopper without removal of the ice machine.

The dispense wheel and sweep arm rotate when the dispense drive motor is actuated. The drive motors actuation is controlled by the agitation timer or the vend switch. When the ice dispense chute is pushed back it moves the actuation lever up. The actuation lever releases the chute door and pushes the vend switch arm up. When the vend switch arm has moved a preset distance the vend switch contacts close, providing power to the dispense drive motor. Ice is delivered to the top end of the ice chute by the dispense wheel and it slides down the chute to the container below.

The container rests on a grill, the grills openings are over the ice catch pan, and any spilled ice goes there. The grill has a flange at the front to help contain the ice if it spills during vending. After the ice dispense chute is released, the ice chute door closes to stop ice flow. Ice in the chute will eventually melt. Melted ice water is routed to the drain through a hose attached to the bottom of the chute. Spilled ice is contained in an insulated ice catch pan. Melted ice water from the ice catch pan is routed to the drain. User debris is kept away from the drain in the catch pan by a slotted shield.

The side and front exterior panels are stainless steel. The vending area and top panel are made of plastic.

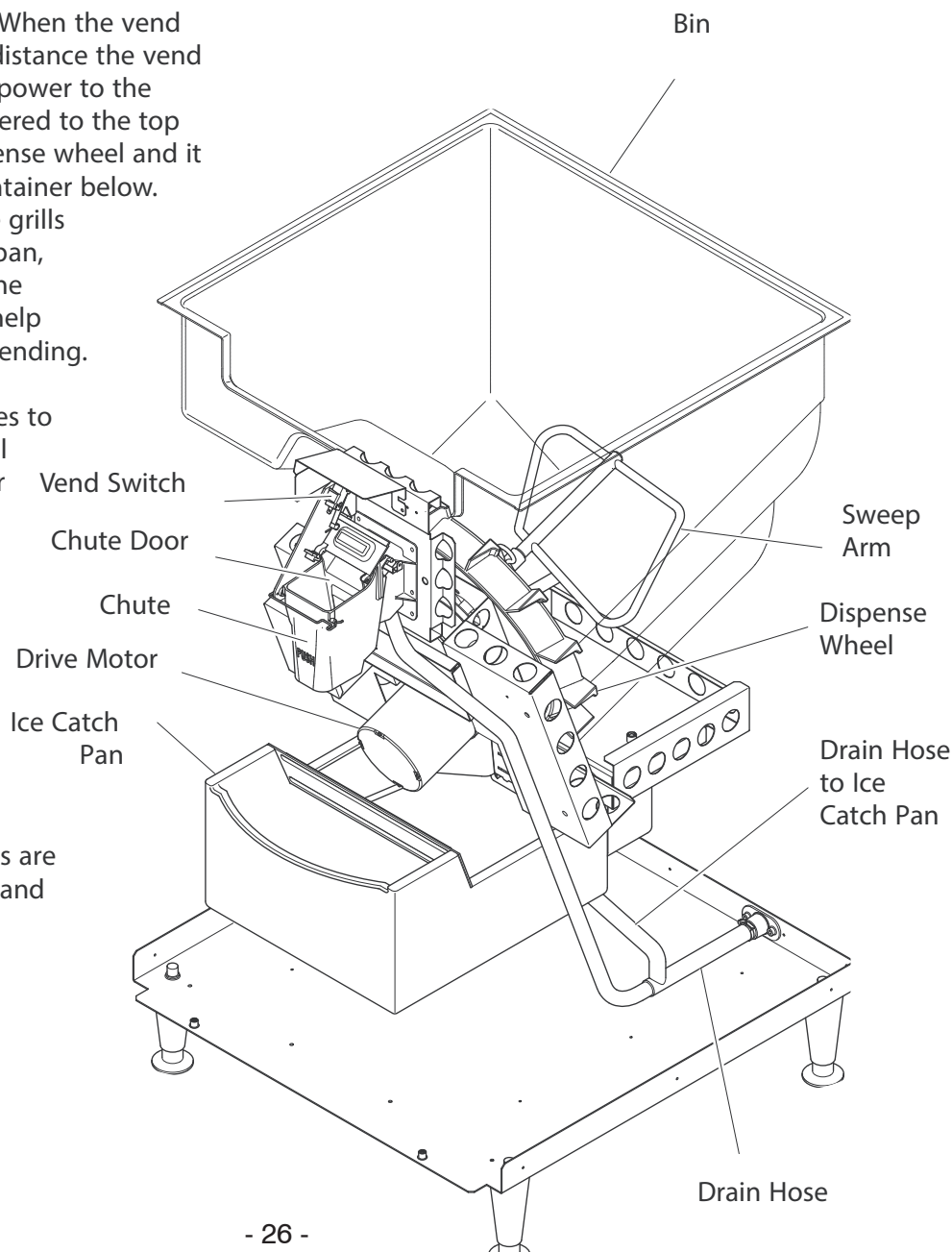

Unpacking

After removing the carton, check for the loose-shipped parts packed in the storage bin. The parts will include a carton with four legs. Remove the leg carton and any other loose-shipped items.

To remove the skid, place part of the carton behind the unit and tip the unit on its back. Remove the bolts holding the skid to the base of the HBN dispenser and separate the skid from the unit.

Install the legs into the base of the unit, using the holes where the skid bolts were. Turn the leg leveler part of the legs in all the way, adjust them later after the unit is in its final installed position.

Move the dispenser to an upright position and set it in the location where it will be installed. Note where drain lines and electrical connections will be made.

Front Panel Removal

The front panel rests on the base and is located with pins that stick up from the base. It is retained to the side panels by strikes and latches. The top panel keeps the front panel from moving forward.

To remove:

1. Disconnect electrical power.
2. Remove the two screws holding the top panel to the dispenser. Lift the top panel up and off the dispenser.
3. Pull the top edge of the front panel forward until the two snaps disengage.
4. Lift the front panel up and off the base.

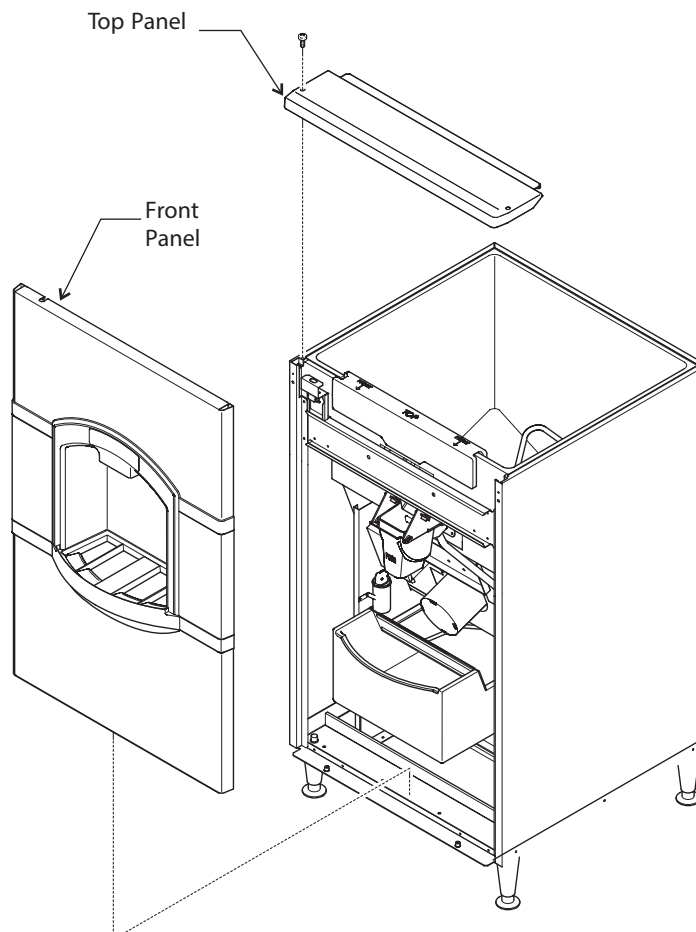

Installation-Plumbing

Drain:

All models of the dispenser have a 3/4" FPT drain fitting at the bottom of the back panel. Connect 3/4" rigid tubing to this connection, a vent is recommended for most installations. Route the drain tubing to the building drain.

Note: Drain fitting material is plastic. If using copper, sweat the copper tube to copper fitting together before installing on the dispenser.

Note: Keep PVC solvent away from all plastic parts of the dispenser.

Follow all applicable plumbing codes.

Because the drain tubing will be very cold, insulation is recommended for the tubing.

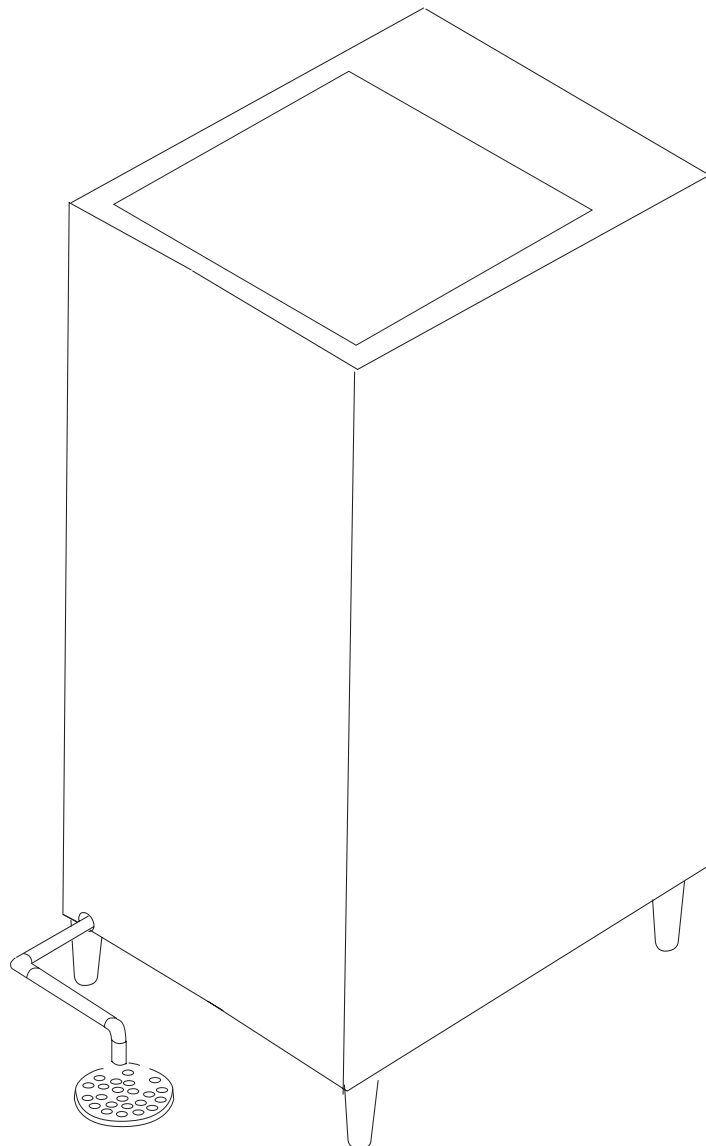

Drain Connection, Back View of Dispenser

Installation-Electrical and Ice Machine Assembly

The dispenser is supplied with a power cord. Do not use with an extension cord. The unit must be plugged into a properly grounded outlet.

The dispenser must be installed so that it is a separate piece of equipment from the ice machine. The drains and electrical supply must be separate.

Follow All Local State and National Codes

Ice Machine

All models: Place the dispenser in the location where it will be used. Level the top edge of the dispenser front to back and left to right ensuring a seal between ice machine and dispenser.

Sanitize the dispenser bin with a locally approved sanitizer. See page 11.

Place the ice machine on the dispenser and secure it to the dispenser with the hardware from 194BKTHBN Kit.

If using a compatible Oceanloch filter system, use the included M4 bolts from 194BKTHBN Kit to attach filter system to the ice machine through the the brackets provided holes.

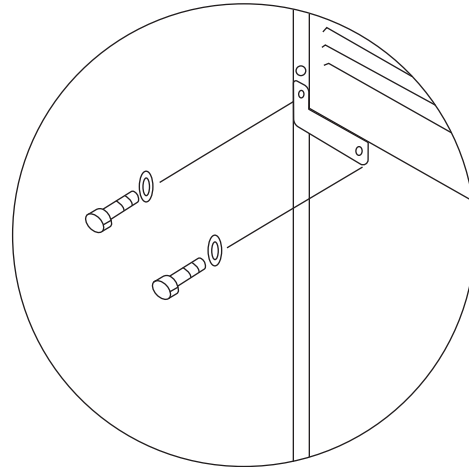

Fasten Ice Machine to Dispenser

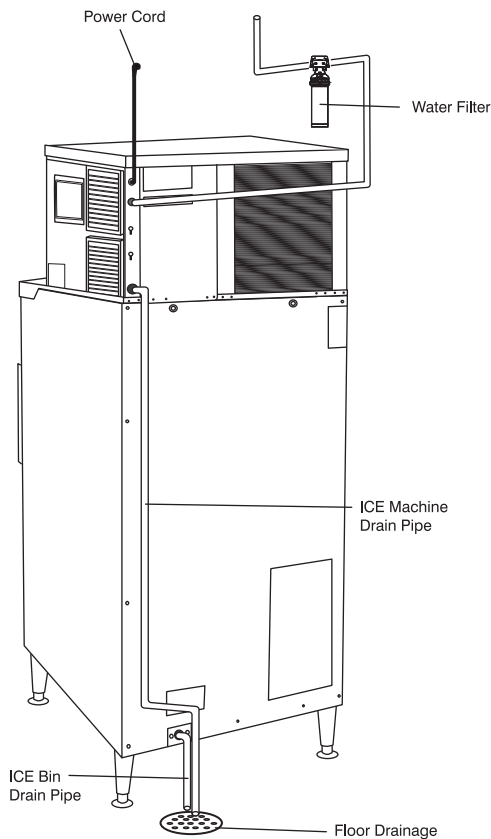

Back View of 194HBN18030 Installation

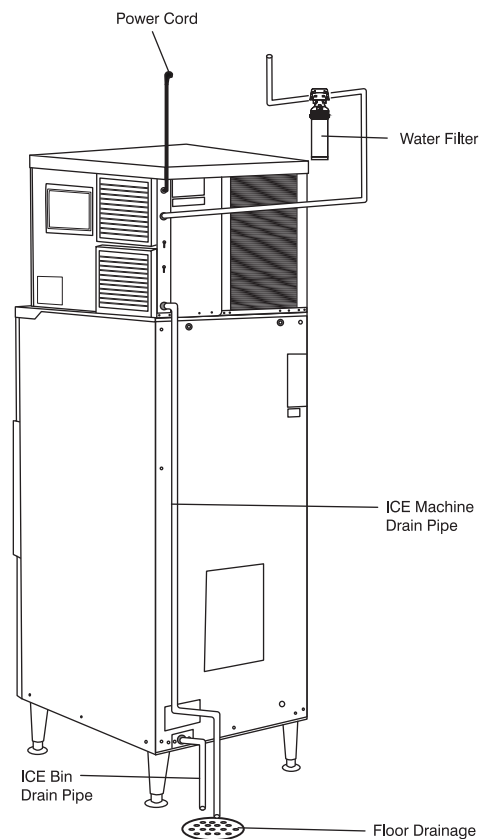

Back View of 194HBN12022 Installation

Final Check List/Initial StartUp

1. Check that electrical power has been supplied.
2. Check that a drain, separate from the ice machine, insulated and made of rigid tubing, has been connected to the dispenser.
3. Check that the ice machine has been properly installed per the ice machines installation directions.
4. Check that the ice machine/dispenser assembly is level front to back and left to right.

To Start:

1. Connect electrical power. The dispensing system will cycle on for a few seconds.
2. Go thru ice machine start up procedures. Let ice machine make two harvests.

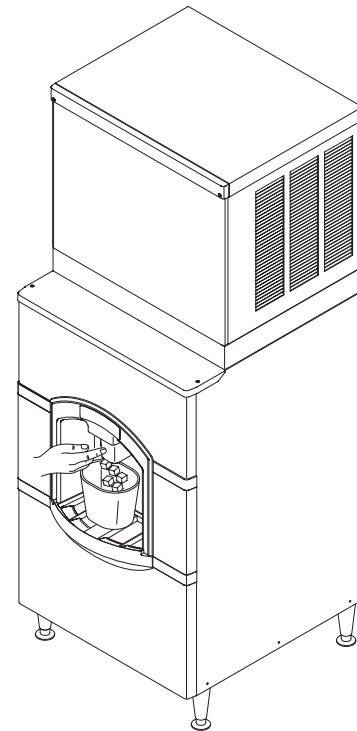

3. Push the ice chute in.
4. Dispense wheel turns.
5. Ice will be dispensed from ice chute.
6. Give the operator any keys and the instructions on the operation and maintenance of the product.

Check that the operator knows who to call for service, and has the product/service manuals for the machines.

Electrical Sequence

Pushing the ice chute closes a contact to the gear motor.

The gearmotor will have power and the dispenser will continue to operate as long as the ice chute is pushed in. This model also has a agitation cycle of 3 seconds every 6 hours. Since the ice chute is not pushed in during agitation no ice is dispensed.

Use

No ice is dispensed.

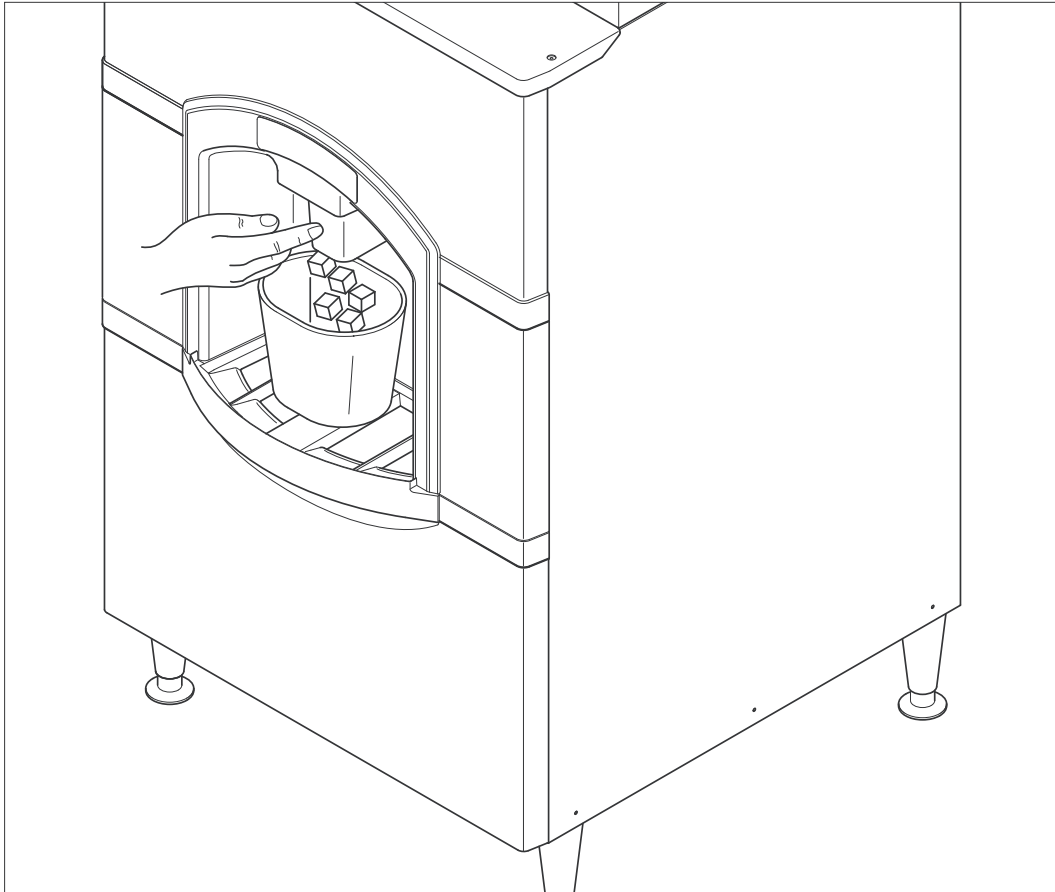

Push the chute back to dispense ice

General Care and Cleaning

Periodically inspect and clean the ice dispenser to keep it operating at peak performance.

Wash the outside of the dispenser with warm water and soap. Rinse off and wipe dry.

Cleaning and Sanitizing of the Ice Storage Bin :

The minerals, chlorine and other impurities in the water are rejected from the water during the freeze cycle of the ice machine. These minerals will collect in the storage bin. The ice storage bin should be cleaned and sanitized every 90 days.

1. Remove all of the ice stored inside the dispenser bin and shut off the ice maker.
2. Disconnect electrical power to the dispenser.

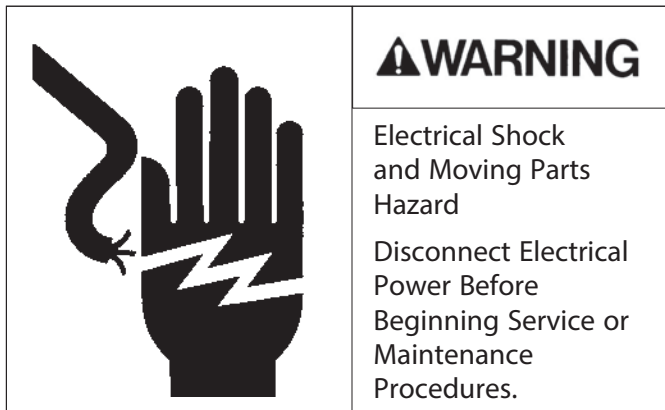

3. Remove top front panel (in front office machine).
4. Remove the front panel.

5. Lift up and remove the access door at the front of the bin
6. Reach into the opening, locate the hair pin and pull it out of the shaft
7. Pull the sweep arm off the shaft and remove it from the dispenser.
8. Pull the dispense wheel off the drive shaft and remove it from the dispenser.
9. Mix a solution of 5 ounces office machine cleaner to 1 gallon of warm (95 °F.-115 °F.) water. Wash the entire bin area and the delivery area. Use a clean brush or cloth.

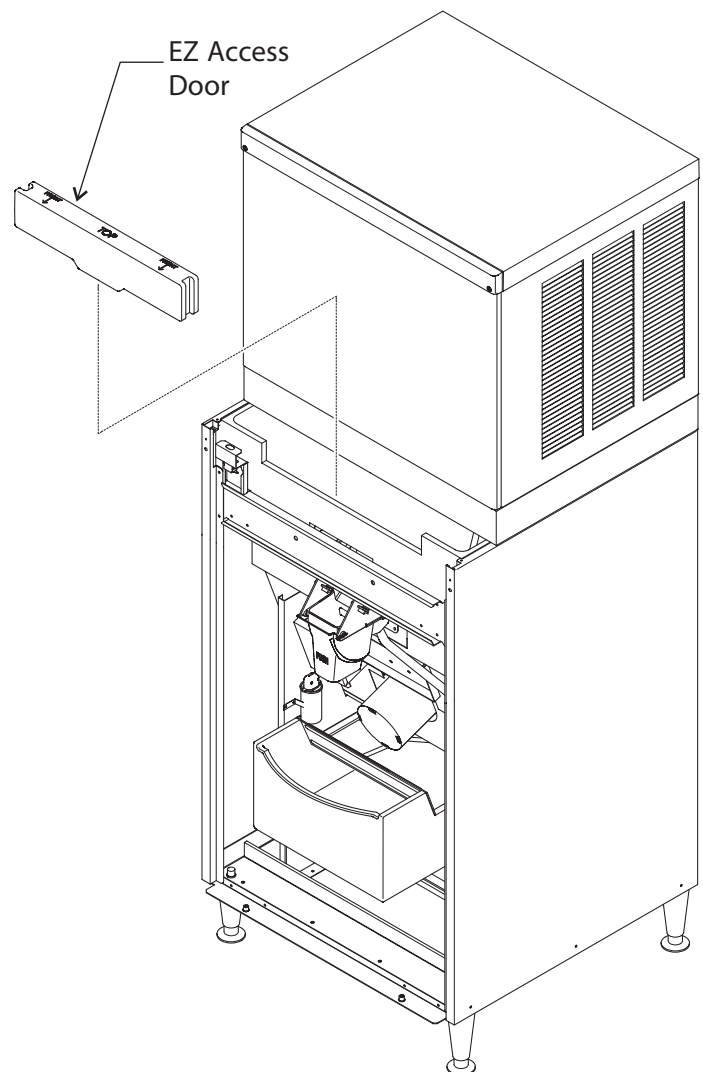

General Care And Cleaning-Continued

10. Rinse all areas washed with clean, fresh water.
11. Using the ice machine cleaning solution, clean the ice grill, sink, sweep arm and dispense wheel. Rinse these parts with clean, fresh water.
12. To sanitize: Use a locally approved sanitizer. A possible sanitizer: Mix a solution of ice machine sanitizer and water: 1 ounce of household bleach to 2 gallons of (95 °F.-115 °F.) water. Wash all interior surfaces, the sweep arm and the dispense wheel with the sanitizer solution. Use a clean cloth.
13. Allow the parts to air dry.
14. Reassemble wheel and sweep arm onto drive shaft. Be sure to reinsert hairpin.
15. Replace all panels.
16. Reconnect power, be sure ice machine is switched back on.

Be sure to clean and sanitize your ice machine following the instructions that came with your ice machine. The cleaning instructions in this manual are only for the ice dispenser.

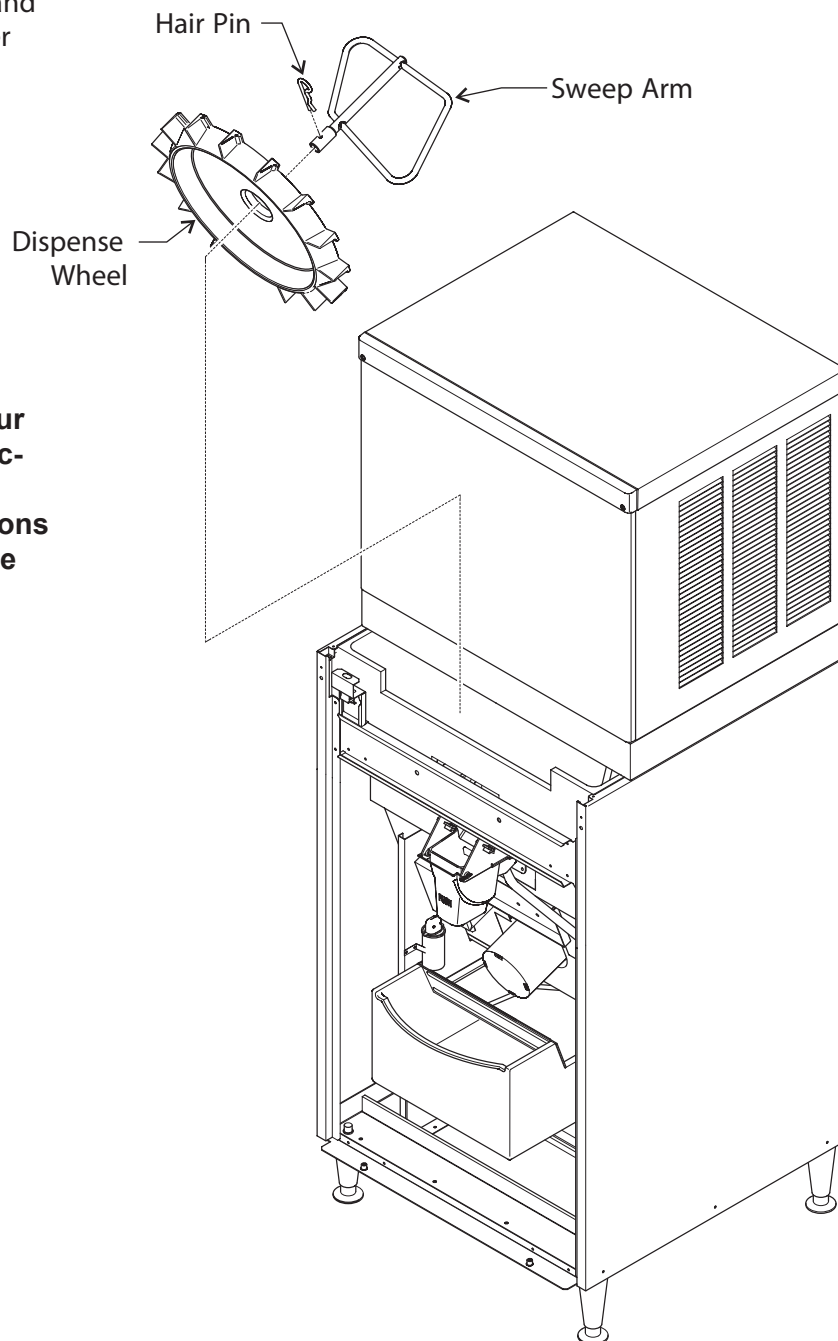

Maintenance

Spilled ice and user debris will collect in the ice catch pan, located just below the sink grill. Occasionally the debris will need to be removed and the drain flushed out to prevent water back ups.

Note: Failure to clean out the ice catch pan will likely result in a water leak, one that is NOT covered by warranty.

To clean out the ice catch pan:

1. Remove the front panel.
2. Disconnect electrical power.
3. Remove the two screws holding the top panel to the dispenser. Lift the top panel up and off the dispenser.

4. Pull the top edge of the front panel forward until the two snaps disengage.

If the unit is a coin op model, reach behind the front panel and disconnect the coin mechanism harness from the front panel.

If the unit is a water station model, reach behind the front panel and shut off the water supply valve to the water faucet. Then disconnect the water line from the shut off valve.

5. Lift the front panel up and off the base.
6. Pull the ice catch pan forward a few inches until the drain hose can be reached.
7. Pull the drain hose from the ice catch pan.
8. Slide the ice catch pan out of the ice dispenser and clear it of any debris. Wash out the drain.
9. Return the ice catch pan to its normal position.
10. Re-attach the drain hose.

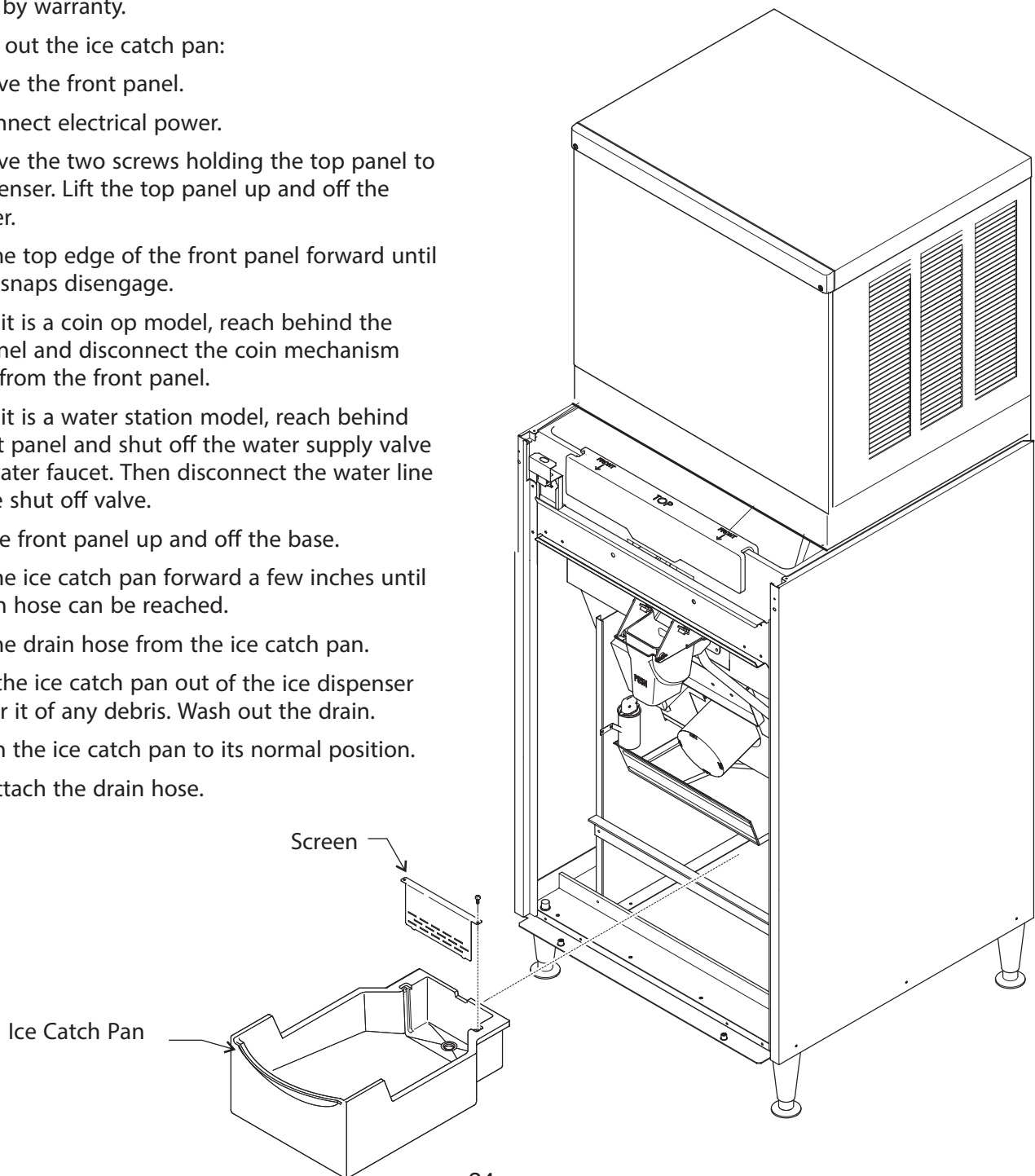

Adjustments

The dispenser is preset at the factory. Adjustments are rarely needed.

Agitation Time Recommendations:

The standard time is 3 seconds on every 6 hours. Adjust to agitate more frequently if the unit is installed in a low temperature environment. However, if the ice being produced by the ice machine is cloudy and crumbles easily, adjust to agitate less frequently.



Agitation Timer, Shown Pre-set to 3 seconds every 6 hours

Service Diagnosis

Symptom	Probable Cause	Possible Fix
No ice is dispensed	No power to dispenser	Check for proper power, is dispenser plugged in?
	No ice	Check ice machine
	Vend switch does not close	Check vend switch Check chute for proper motion
	Chute cannot be pushed back	Check door lock for proper operation
	Interlock switch open	Check interlock switch, be sure top panel is in place
	Drive motor windings open	Check drive motor
	Drive gears failed	Check gear reducer
No ice is dispensed	Same as above plus coin switch does not close	Check coin switch
	Vend timer does not work	Connect power to post 6 of coin mech timer, timer should activate, ready light should be on and pushing the chute should start the gear motor, if not replace the vend timer
Only dispenses small amount of ice	Sweep arm damaged	Check/replace sweep arm
No water is dispensed	Water shut off	Check water supply to unit, check shut off valve inside cabinet
Water leak	Drain is plugged	Check drain for restriction
	Ice catch pan has overfilled	Remove excess ice
	Ice catch pan screen is plugged	Clean screen
	Seal between ice machine and dispenser is leaking	Remove ice machine and replace gasket tape
Water drip from spout	Some dripping is normal, but if severe	Check spout drain for restriction
"Ready" light is on all the time	Resistor is open	Replace resistors (15K, 2 watt in parallel)