

Item #: 178SSPT60A Project: \_\_\_\_\_

Qty: \_\_\_\_\_ Date: \_\_\_\_\_ Approval: \_\_\_\_\_



## Avantco SS-PT-60-HC 60" 2 Door Stainless Steel ADA Height Refrigerated Sandwich Prep Table

Item #178SSPT60A



### Technical Data

Width	60 1/4 Inches
Depth	31 Inches
Height	44 1/4 Inches
Interior Width	56 1/4 Inches
Nominal Width	60 Inches
Interior Depth	23 3/4 Inches
Interior Height	23 1/2 Inches
Work Surface Height	33 5/8 Inches
Amps	2.4 Amps
Phase	1 Phase
Voltage	115 Volts
1/6 Size Pan Capacity	16 Pans
Access Type	Doors
BTU (LBP)	1285
Capacity	15 cu. ft.
Casters	With Casters
Color	Silver
Compressor Location	Side Mounted
Compressor Style	Side / Rear Breathing
Door Style	Swing
Door Type	Solid
Features	ADA Compliant
Hinge Location	Left/Right
Horsepower	1/2 HP
Number of Doors	2 Doors
Number of Shelves	2 Shelves
Plug Type	NEMA 5-15P
Refrigerant Type	R-290
Sections	2 Sections
Style	ADA Height
Temperature Range	33 - 40 Degrees F
Top Type	Standard Top

### Features

- 2 1/2" casters make moving simple for easy cleaning and bring the unit to an ADA-compliant working height
- Top accommodates (16) 1/6 size, 6" deep food pans
- Industry-best 3/4" cutting board is built-in for convenient prep space and removable for cleaning
- Digital control with auto defrost
- 115V; 1/2 hp; 2.4 Amps
- 2 year Parts and Labor Warranty ensures long-lasting peace of mind

### Certifications



5-15P



ADA Compliant



ETL Sanitation



ETL US & Canada

Avantco Refrigeration

## Plan View

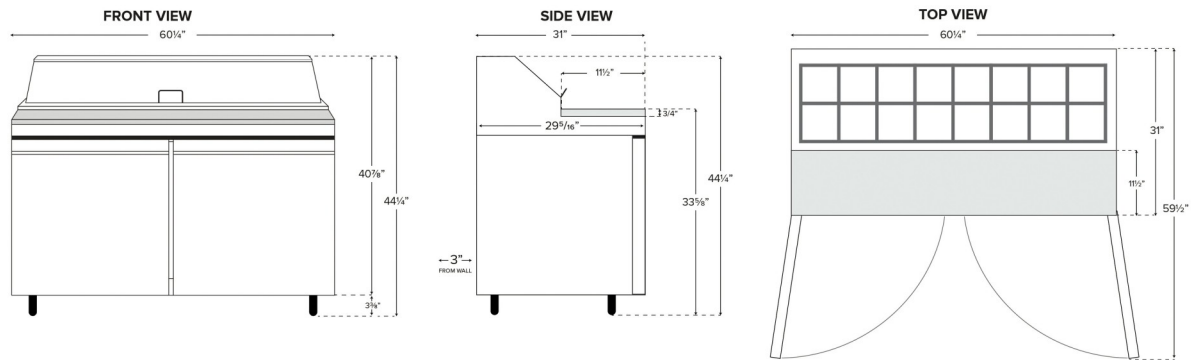

## Notes & Details

Optimize your back-of-house operations with this Avantco SS-PT-60-HC 60" 2 door stainless steel refrigerated sandwich prep table, and better keep up with customer demands. Whether used in a university, sub shop, or hospital, the unit is sure to help streamline the sandwich prep process with its convenient features and capacity. Its top, for instance, accommodates up to (16) 1/6 size food pans up to 6" deep (sold separately). These are great for holding common sandwich or salad toppings, from eggs and cheese to green pepper or ham. Plus, a lift-up lid encloses the top to maintain proper, food safe temperatures. A full-length cutting board, which is 11 1/2" deep, is mounted to the table surface, providing a place for slicing ingredients and assembling orders.

Beneath the workspace is additional storage space. Because it's refrigerated, the space is great for storing back-up ingredients, such as deli meat and cheese, as well as less common toppings. Two epoxy-coated shelves are included and can each accommodate up to 90 lb. of weight, helping to organize your assorted supplies. Divider bars are also included for ultimate convenience.

High quality performance is made possible by the unit's 1/2 hp refrigeration system, which maintains temperatures between 33 and 40 degrees Fahrenheit. It does this by circulating eco-friendly R290 refrigerant. This specialized refrigerant has an ozone depletion potential (ODP) of 0 and a global warming potential (GWP) of 3, making it an environmentally-responsible choice for your business.

The construction of this unit is designed with commercial use in mind. It features a 430 type stainless steel exterior and 304 type stainless steel interior, which are fortified with foamed-in-place polyurethane insulation. The insulation also helps to promote proper temperature retention. For operation, the prep table requires a 115V electrical connection.

**⚠ WARNING:** This product can expose you to chemicals including lead, which are known to the State of California to cause cancer, birth defects, or other reproductive harm. For more information, go to [www.p65warnings.ca.gov](http://www.p65warnings.ca.gov).