

Avantco DLC47-HC-S 47" Stainless Steel Curved Glass Refrigerated Deli Case

Item #178DLC47HCS



Technical Data

Width	47 1/4 Inches
Depth	32 1/2 Inches
Height	42 7/8 Inches
Interior Width	43 1/4 Inches
Interior Depth	26 3/4 Inches
Interior Height	26 3/4 Inches
Amps	3.14 Amps
Voltage	115 Volts
BTU (LBP)	1092
Capacity	13.5 cu. ft.
Color	Silver
Compressor Location	Bottom Mounted
Display Case Type	Refrigerated
Door Style	Sliding
Features	LED Lighting Lighted Interior
Glass Style	Curved
Horsepower	1/2 HP
Installation Type	Floor Model
Number of Doors	2 Doors
Number of Shelves	6 Shelves
Number of Tiers	3 Tiers
Plug Type	NEMA 5-15P
Refrigerant Type	R-290
Refrigeration Type	Gravity Coil
Service Type	Full Service
Temperature	33 - 40 Degrees F
Type	Deli Cases

Features

- Curved glass front and LED lighting to best showcase fresh deli product
- Strong and sleek stainless steel exterior with a 21" deep countertop for convenient workspace
- Six epoxy coated shelves; four are adjustable to accommodate different sized products
- Digital controller for easy operation and automatic defrost for easy maintenance
- Uses eco-friendly R290; 1/2 hp, 115V; 3.14 Amps

Certifications



ETL US



ETL Sanitation



5-15P

Plan View

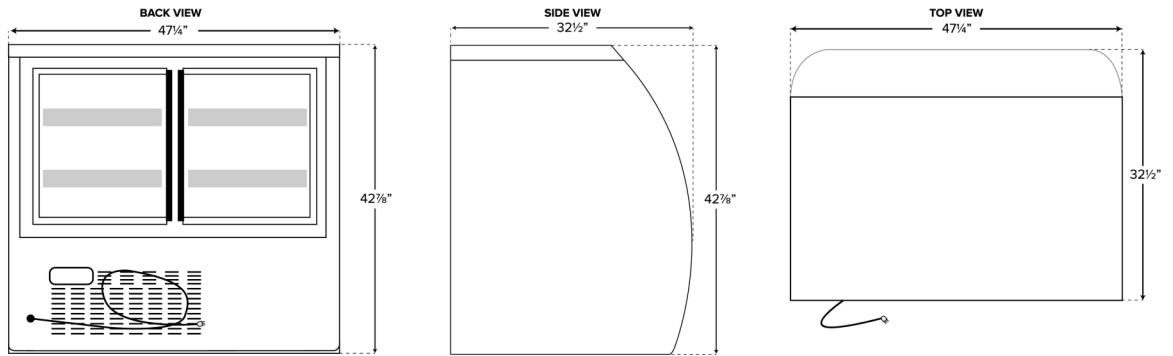

Notes & Details

Attractively present your fresh cheese, meat, and other refrigerated deli items with the Avantco DLC47-HC-S 47" stainless steel curved glass refrigerated deli case! With a smooth, curved glass design, this contemporary case keeps contents sanitary while beautifully displaying them on six epoxy-coated shelves. Crisp, internal LED lighting provides superior visibility for your products. Having a deli case is sure to boost your impulse sales, because customers can clearly see the products you're offering behind the strong, damage-resistant glass front. A stainless steel exterior combines with the painted aluminum and 304 stainless steel interior for long-lasting durability.

For optimal temperature retention, this deli case features foamed-in-place polyurethane insulation that protects the integrity of your refrigerated goods. A 1/2 hp compressor keeps the unit operating at temperatures between 33-40 degrees Fahrenheit, while circulating R290 refrigerant. This specialized refrigerant has an ozone depletion potential (ODP) of 0 and a global warming potential (GWP) of 3, making it an environmentally-responsible choice for your business. The digital temperature controller ensures quick temperature readability, and for convenience, the unit has an auto defrost function. A 115V electrical connection is required for operation.

⚠ WARNING: This product can expose you to chemicals including lead, which are known to the State of California to cause cancer, birth defects, or other reproductive harm. For more information, go to www.p65warnings.ca.gov.