

Item #: 178SSWD3RI Project: _____

Qty: _____ Date: _____ Approval: _____

Avantco 93" Stainless Steel Extra Deep Worktop Refrigerator with 3 1/2" Backsplash with 2 Left Drawers and 2 Doors

Item #178SSWD3RI



Avantco Refrigeration

Features

- Strong and sleek type 430 stainless steel exterior with type 304 stainless steel interior
- Foamed-in-place polyurethane insulation maintains temperatures from 33 to 40 degrees Fahrenheit
- 3 1/2" backsplash for wall protection
- Includes 2 left-side drawers, 2 doors, and 6 divider bars
- 115V; 1/2 hp; 3.14 Amps

Certifications



5-15P



ETL Sanitation



ETL US



Technical Data

Width	93 13/16 Inches
Depth	31 1/2 Inches
Height	38 Inches
Power Cord Length	98 Inches
Interior Width	73 1/4 Inches
Packaging Width	96.5625
Shelf Width	23.149999618530273 Inches
Depth with Door Open	55.0625
Interior Depth	26 3/16 Inches
Packaging Depth	34.25
Shelf Depth	24 2/5 Inches
Interior Height	22 7/8 Inches
Packaging Height	39
Work Surface Height	35 1/4 Inches
Amps	3.14 Amps
Hertz	60 Hertz
Phase	1 Phase
Voltage	115 Volts
Access Type	Doors and Drawers
BTU (LBP)	809
Capacity	25.4 cu. ft.
Compressor Style	Front / Rear Breathing
Door Style	Swing
Door Type	Solid
Features	Automatic Electric Defrost Digital Temperature Controller With Backsplash
Hinge Location	Left/Right
Horsepower	1/2 HP
Individual Shelf Capacity	90 lb.
Insulation Material	Polyurethane Foam
Material	Stainless Steel
Maximum Ambient Temperature	90 Degrees F
Net Weight	342 lb.
Number of Doors	2 Doors
Number of Drawers	2 Drawers
Number of Shelves	1 Shelves
Plug Type	NEMA 5-15P
Refrigerant Type	R-290
Style	Counter Height
Temperature Range	33 - 40 Degrees F

Plan View

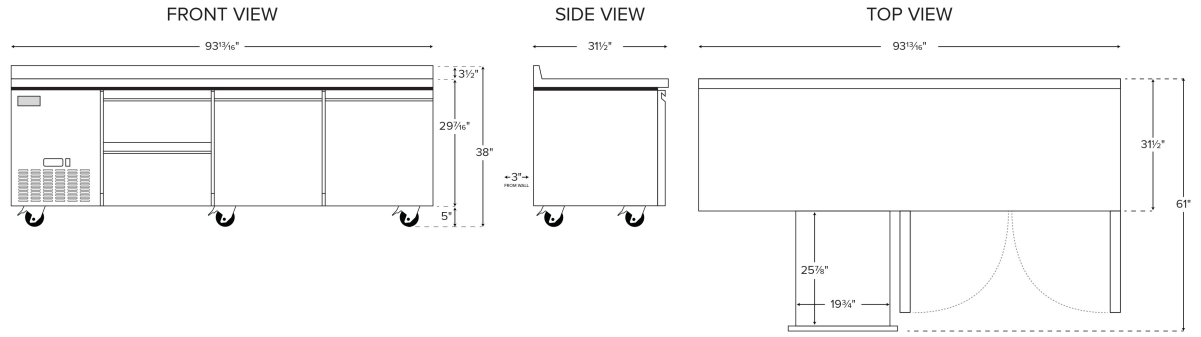

BIG DRAWER SIDE SIDE VIEWS

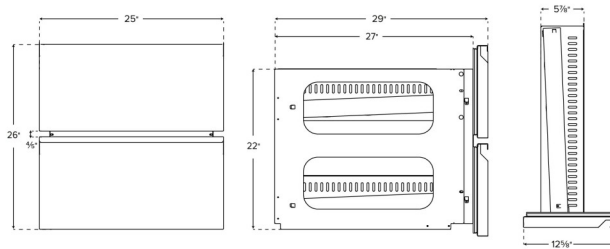

BIG DRAWER TOP VIEWS

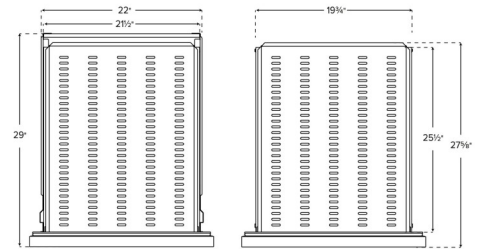

Avantco Refrigeration



Notes & Details

Make food preparation as convenient as possible with the Avantco 93" extra deep worktop refrigerator. With a spacious stainless steel worktop surface for slicing, dicing, assembling, mixing, and other food prep tasks, the unit features a 3 1/2" backsplash for wall protection and a refrigerated storage space below. The refrigerated portion is readily accessible through 4 drawers, 2 on each side, and 1 door in the middle. This door opens to an epoxy-coated steel shelf to help organize product. Drawers provide excellent organization for your food pans and can help maximize your kitchen's workflow. Drawers also allow you to quickly pull ingredients for faster operation and ease of use. Plus, 12 assorted divider bars are included, which fit in the drawers where they act as braces for full size or fractional pans. Easily reconfigure or remove the braces to best suit your inventory. Providing 25.4 cu. ft. of space in total, the refrigerator makes it easy to store fresh produce, condiments, and a range of other ingredients needed for the prep station.

This refrigerated unit is designed for outstanding durability to ensure that it withstands tough, busy kitchen environments with ease. It features a 430 type stainless steel exterior, which provides both strength and a smooth, sleek appearance. The interior, made with 304 type stainless steel, also offers the durability necessary for heavy, regular use.

This worktop refrigerator ensures optimal performance by operating with a 1/2 hp refrigeration system that circulates environmentally-friendly R290 hydrocarbon refrigerant to maintain temperatures from 33 to 40 degrees Fahrenheit. R290 refrigerant has an ozone depletion potential (ODP) of 0 and a global warming potential (GWP) of 3, making it an environmentally-responsible choice for your business. The foamed-in-place polyurethane insulation helps to trap in the cold air and to prevent the ambient air from entering. This ensures that all food held in the unit remains at food safe temperatures and ready for preparation or direct service to customers!

Operation of the refrigerator is easy, thanks to its special features. Monitor it by consulting the interior wall-mounted thermometer, and use the auto-defrost feature on the pre-programmed digital controller to maintain the refrigerator in tip-top shape. At the end of the day, take advantage of the casters and roll the unit aside to thoroughly clean the area. This worktop refrigerator requires a 115V electrical connection for operation.

⚠ WARNING: This product can expose you to chemicals including lead, which are known to the State of California to cause cancer, birth defects, or other reproductive harm. For more information, go to www.p65warnings.ca.gov.